

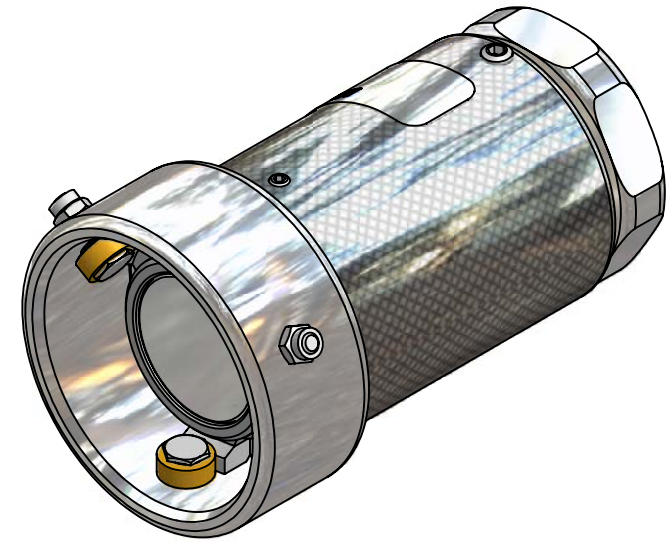

Notice: This drawing contains proprietary information and shall not be used or reproduced or its contents disclosed in whole or in part, without the prior written consent of the Mann Teknik AB

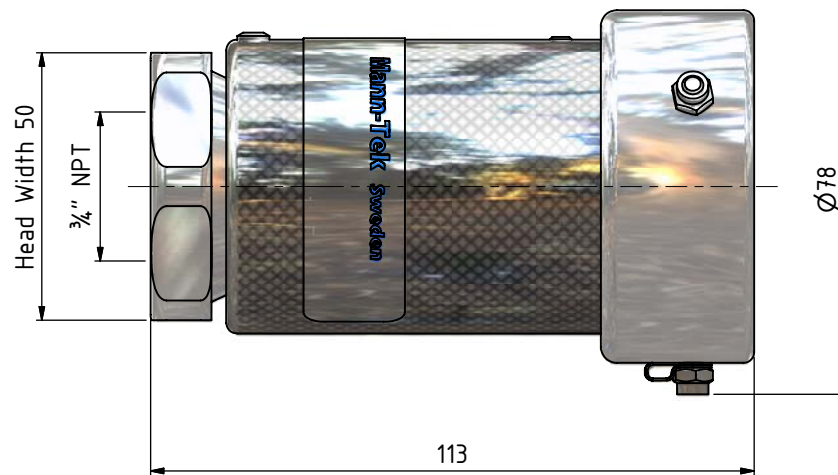
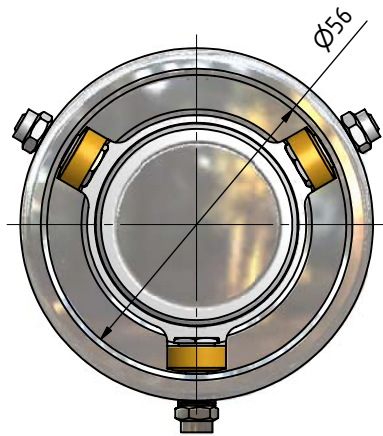

Dimensions are in metric.

| | | | |
|---------------------------------------------------------------------------------------|--------------------------------|--------------------|--------------------------------------------------------------------------------------------------------------------------------------------------------------------------|
| Detail No: | Material | Ytbeh./Treatment | |
|  | Designed/drawn by P. Nyberg | Scale: 1:1 | Dimension with no tolerances acc to Machined SS-ISO 2768-1 medium Weld Forge SS-ISO 2768-1 coarse Surface roughness ISO 1302 Form & position tol SS ISO 1101 |
| | Checked G. Kopplin | Date 2007-05-14 | |
| | Approved T. Mann | | |
| Hose Unit 1" Connection: 3/4" NPT | | | Data nr./Comp No. S102A1101 Blad/Sheet 1 / 1 |
| | | | Drawing No. S102A1101-1 Rev. |

| | | | | |
|-----|--------------------|------|-------|---------|
| NO. | Revision comprises | Date | Sign. | Appr by |
|-----|--------------------|------|-------|---------|